

MODIFRY PRODUCTS S2000 Seat Belt Lock (Remote Kit)

Caution - This product is to be used ONLY on the Honda S2000 and is intended to provide increased driver support when using the stock lap belt and shoulder harness. It is NOT to be used as a replacement for competition belts or at any event where 4 or 5-point restraint systems are required.

This product uses an electro-magnet to activate the factory inertia-sensing mechanism built into the seat belt assembly. It does not alter the factory restraint system in any way and has no effect on the seat belt retractors or air bag system. It simply activates the "tilt" mechanism built into the seat belt, the one that normally kicks in only when you corner or brake very hard. Modifry's Seat Belt Lock is relatively easy to install and can be quickly removed, leaving no trace it was there.

Installation

1. Prepare - Empty the trunk of anything breakable or that might get in the way of sitting in the trunk (really). Remove the spare tire access panel and the spare tire. Then slide and tilt the passenger seat as far forward as it will go. Note – I use the abbreviation "SBL" for the Seat Belt Lock, which is the black bracket with the electro-magnet attached.

2. Remove the access panel behind the passenger seat.

Unsnap the screw covers on the two plastic hooks and then remove the screws. Carefully pull the panel out, starting at the bottom and working around the outer edge to release the clips that hold it in place.



3. Locate the accessory power socket wire harness.

This wire loom goes under the glove box on the right. Pry apart the plastic (it's split down the middle) and pull the black and white/red wires out in preparation for attaching the T-taps. If the two wires are not black and white/red STOP, you have the wrong wire loom.



4. Attach T-taps to both the black wire and the white/red wire. Make sure the wire is positioned in the groove of the metal part of the T-tap and close the pliers until the locking tab snaps closed. Here's a photo using regular pliers (opened up to the wide-jaw position) to clamp the T-taps.

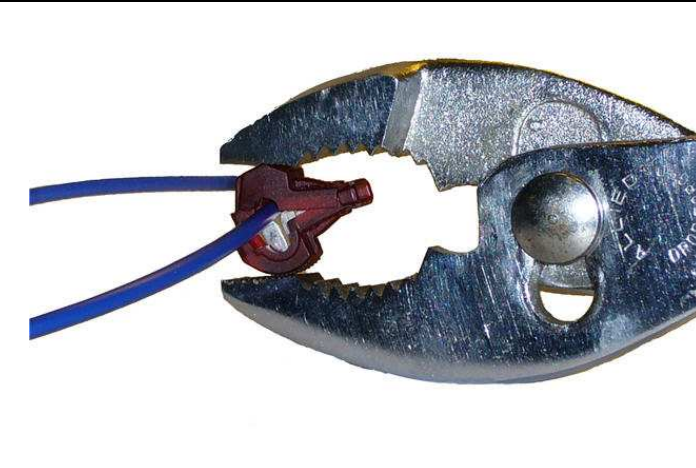

5. Plug in the SBL Control Box Wires as shown below. These are the SINGLE wires, not the "paired" zip cord wires. The SBL single black wire goes to the T-tap on the black wire and the SBL single red wire goes to the T-tap on the white/red wire.



MODIFRY PRODUCTS S2000 Seat Belt Lock (Remote Kit)

6. Push zip cord into trunk – Refer to the photo for step 5 and push the free end of the red/black zip cord up under the fiber insulation and into the trunk. Leave the wire loose so it can be pulled through from the trunk side.

7. From the trunk, pull the zip cord through. Pull about 2 or 3 feet of wire into the trunk and plug the connector on the end of the zip cord into the SBL. The plug only goes in one way and be careful not to bend the wire terminals on the SBL. Once it's plugged in, bend the stiff part of the wire in a "U" shape so the wire goes over the top of the SBL and to the right, as shown in the bottom left of this photo.

8. Locate the seat belt assembly by looking above the gas tank for the blue cover on the bottom of the assembly. The good news is you don't have to remove it, just reach up under the rear shelf to clip the SBL to it. The SBL holds by magnets so no screws or bolts are needed.



Take a minute to review the next few photos to get a feel for how the SBL mounts to the seat belt assembly. The seat belt assembly has a large square nut on the right side of the bracket and the SBL is designed to fit over the nut. Because you cannot directly see the nut you will have to place the SBL over the nut by feel. Fortunately this not very hard to do and shouldn't take more than a minute or two once you get in position.

Be careful with the SBL as the magnets are extremely strong and can damage painted metal surfaces if allowed to come in contact with them. I suggest leaving the SBL wrapped in the cardboard until you are ready to mount it.

This is what you'd see if you were 2" tall and standing on the gas tank. The important part is the square nut on the right side of the bracket – that's where the SBL mounts.

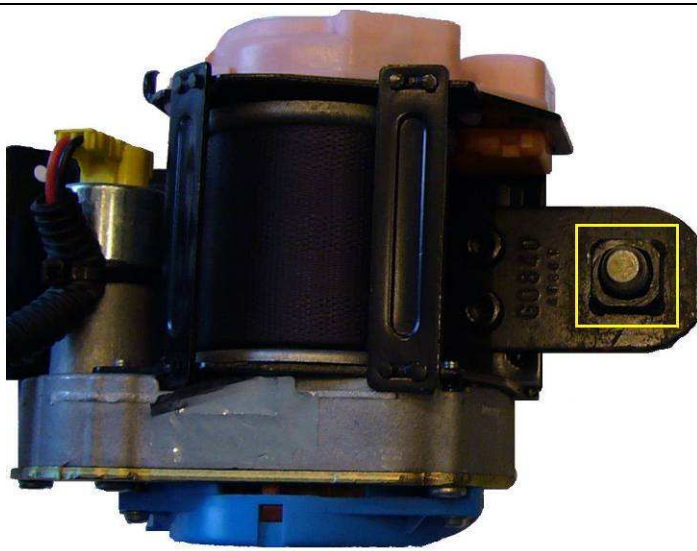

This photo shows how the SBL attaches. The yellow rectangles mark where the two magnets will end up once the SBL is placed in position over the square nut.

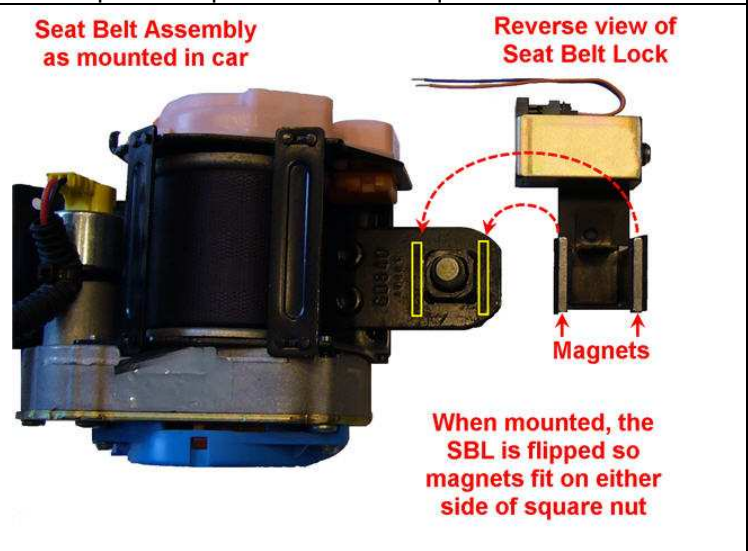

9. Attach the SBL – Sit or lie in the trunk and reach up under the rear shelf with your right hand. It helps to first locate the square nut by feel. Then, avoiding any other metal surfaces, pick up the SBL, position it over the square nut and slide the SBL completely over the nut so it holds itself in place. Watch your fingers – those magnets are very strong and can pinch if you're not careful. It may take a little wiggling to get the SBL positioned over the nut but it will be obvious once it snaps into place.

If you could see the final assembly this is what it would look like. Make sure the wires do not get caught between the SBL and the seat belt assembly. If the SBL does not seem to fit correctly, remove the electro-magnet and see if the bracket fits by itself. If it does, you may need to adjust the electromagnet by loosening the Philips screws and sliding it to the right. Not too far, just enough to clear - you want it as close as possible to the pink housing.



10. Mount the SBL box and clean up your wiring – Using the alcohol pad, clean one side of the SBL box and the flat area of the center support. When dry, attach the Velcro strips and position the SBL box so it won't interfere with the access panel when it's installed. Use the provided wire ties to bundle the excess wire and neaten up the installation.

In the trunk, make sure the zip cord is routed away from the spare tire and won't be pulled or crushed when the tire is put back in the car. You can pull the excess wire out of the trunk and bundle it behind the access panel but don't put any strain on the cable going to the SBL.

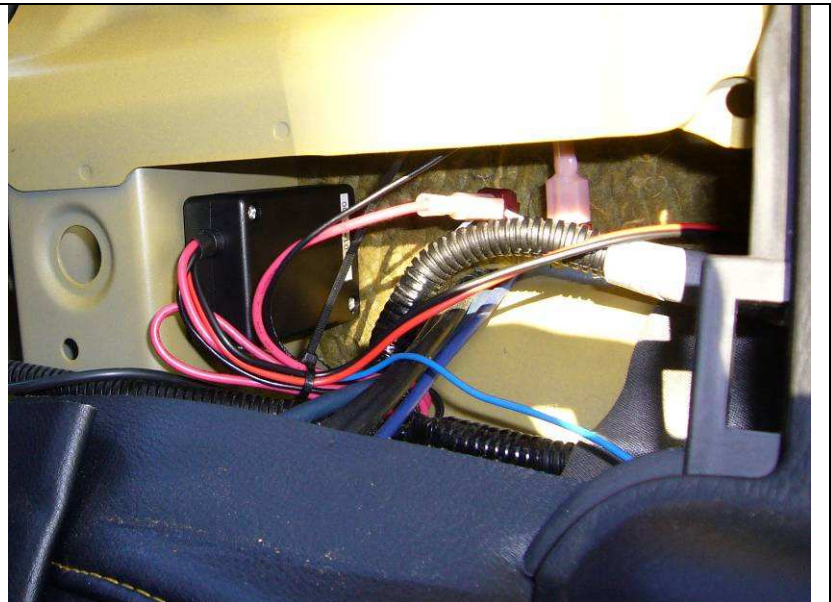

11. Test the SBL – Sit in the driver's seat and put on the seat belt. Turn the ignition to the ACC or ON position and press the "ON" button on the keychain remote. The seat belt should be locked and should not pull out of the reel. Push yourself back into the seat and feed the belt slack into the reel over your left shoulder. The slack should stay there – effectively locking you in the seat.

NOTE - To release the SBL you must first turn off the SBL via the keychain remote (or the ignition key), then feed a little slack into the reel to release the ratchet mechanism. Once the ratchet is released the belt will return to normal operation. If it's difficult to feed the slack into the reel you can release the belt by pushing the button on the seat belt buckle. You have to push hard because of the tension on the belt but it will release with just a little effort.