

The DCI does NOT work like the factory dash controls so review the Operation section before using it. Installing a DCI requires the same skills and tools as installing a new head unit. If you have trouble understanding the wiring diagram or you aren't sure how to wire the DCI you should seek professional help (from an auto installer). DCIs are fully tested on a head unit using S2000 dash controls before shipping. Wiring errors will damage the DCI and are not covered by warranty. Be careful; do not assume "color-to-color" wiring. For additional information, troubleshooting help, or to return products for repair or refund, see the Trouble section on the last page of this manual.

Installation – If you have a PnP harness just plug everything together and skip this page. If you have a Modify Adapter connect the DCI red, black, green, and purple wires to the 4 extra-long wires on the adapter. Leave the wires full-length so you can put the DCI behind one of the side panels on the radio console or under the dash. That makes for easy access if you need to change the dip switches at a later date. If you have a generic harness adapter it won't have the extra wires for the DCI. You'll have to splice the DCI red and black wires into the switched power wires for the head unit, and then splice the DCI green and purple wires directly into the factory stereo harness green/red and yellow/blue wires (as if the "Modify Adapter" in the below diagram were missing). The DCI Gray and Blue wires are optional and are described in detail below.

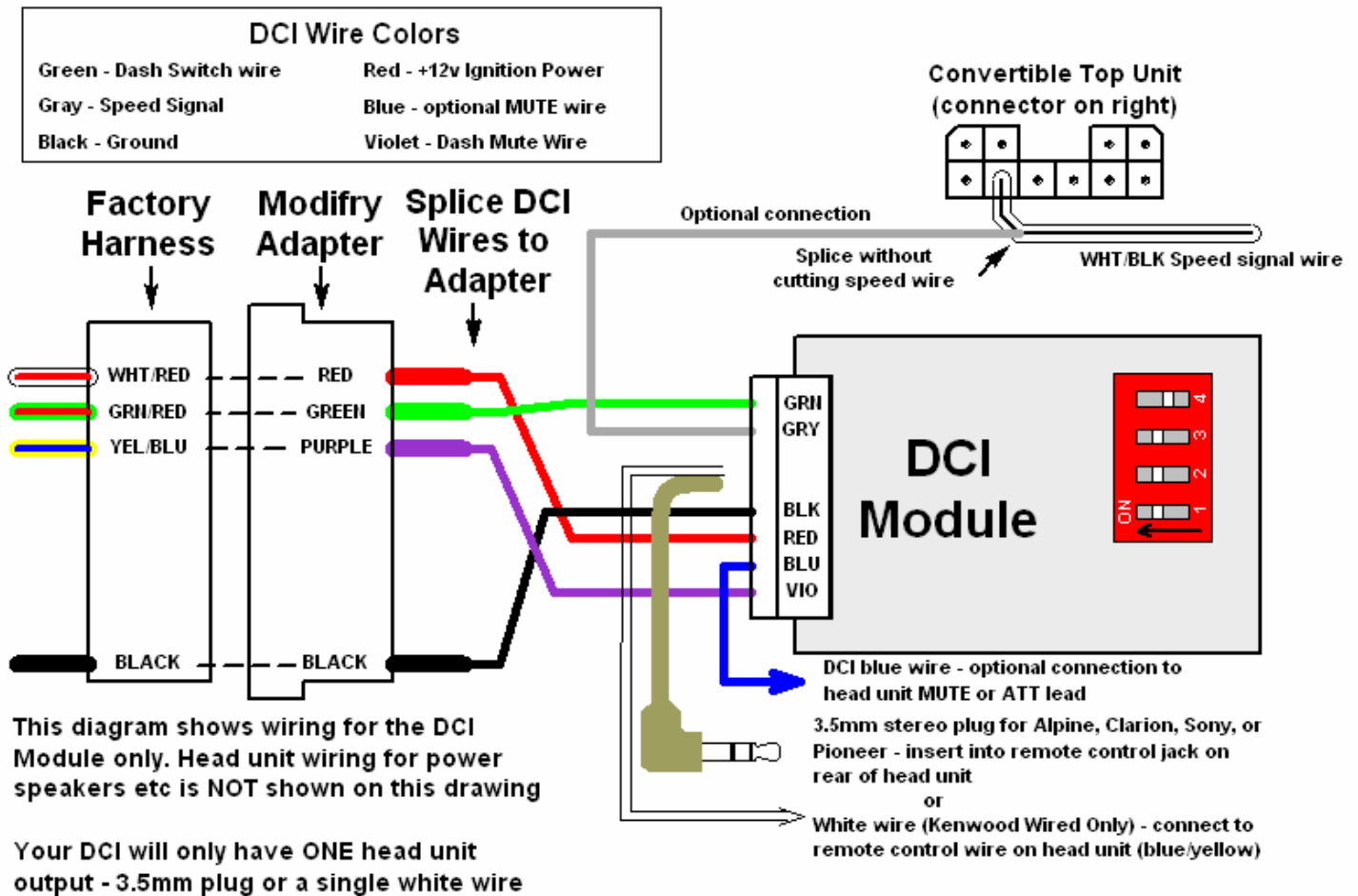

Blue wire - Mute connection - The DCI normally performs the mute function via the blue wire which should be connected to your head unit's ATT or Cell Phone lead. With most head units this will pause CD playback and lower the volume to zero. If your head unit does not have a separate ATT or Cell Phone wire, or if you have a Blue Tooth adapter that connects to the you must insulate the DCI blue wire to prevent accidental shorts and change dip switch 1 to ON (up) so the DCI sends the MUTE command via the 3.5mm cable.

White wire – Only on Kenwood Wired DCI – connect to the "remote control" wire on Kenwood head unit (blue/yellow).

Gray wire - Optional SCV connection (Speed-Controlled-Volume) - All DCIs have this feature that adjusts volume based on vehicle speed. If you don't want to use it, simply insulate the DCI gray wire and it will be disabled. To use SCV you must extend the DCI gray wire and connect it to the vehicle speed signal wire located behind the passenger dash as shown in detail on the next page. You can then adjust the degree of volume compensation by following the SCV programming instructions on page 5.

Connecting to the Vehicle Speed Signal for the SCV feature (Speed-controlled-volume)

If you don't want to use the auto-volume feature skip this section.

1. Extend the DCI **gray** wire with a piece of 18 to 22 gauge wire and run it behind the passenger dash for connection to the speed signal wire. The speed signal is available at the Convertible Top Module located behind the passenger dash access panel, shown in photo 1, with the 6 snaps that hold it in place identified by yellow circles.
2. Remove the access cover using a non-metal pry tool so you don't scratch the plastic. If the cover has not been off before or the dash is very cold, the snaps may be fairly tight so be careful to avoid cracking the plastic cover.
3. Locate the Convertible Top Module, which is a black box with a blue label. It has 2 wiring connectors on the bottom side. Separate the wires on the right connector and look for a **white/black** wire on the bottom row of wires. It's identified in photo 2 with the yellow arrow.
4. You will need to splice (T-tap) the extended DCI **gray** wire into the **white/black** wire as shown in photos 3 and 4. Do not cut the white/black wire; it prevents the convertible top from being operated if the vehicle is moving. If the white/black wire were cut near the Top Module and the DCI connected to the opposite end of the speed signal wire, the DCI would see the speed signal but the Top Module wouldn't. This would allow the top to be lowered with the vehicle moving (assuming you pulled the hand brake up one click), which is a safety hazard. Don't do it!

Photo 1 showing passenger dash access cover



Photo 2 – Convertible Top Module and Speed Signal Wire

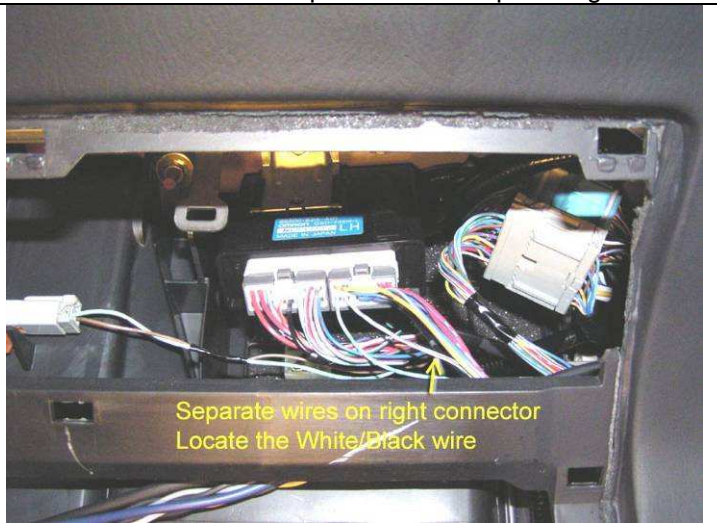

Photo 3 – putting a T-tap connector on the speed signal wire.

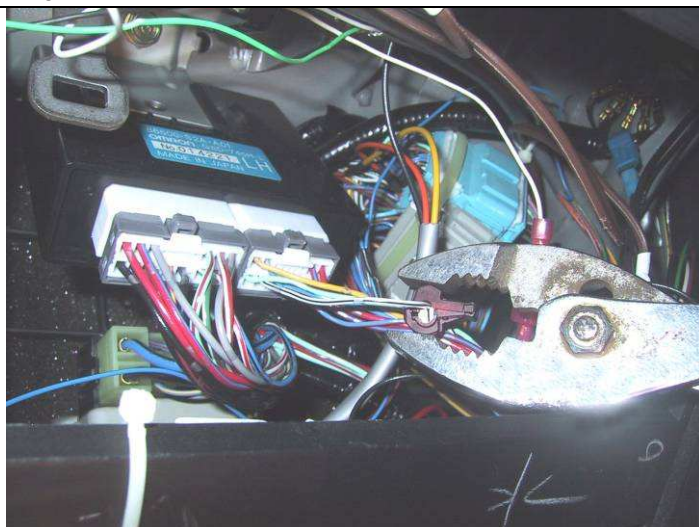
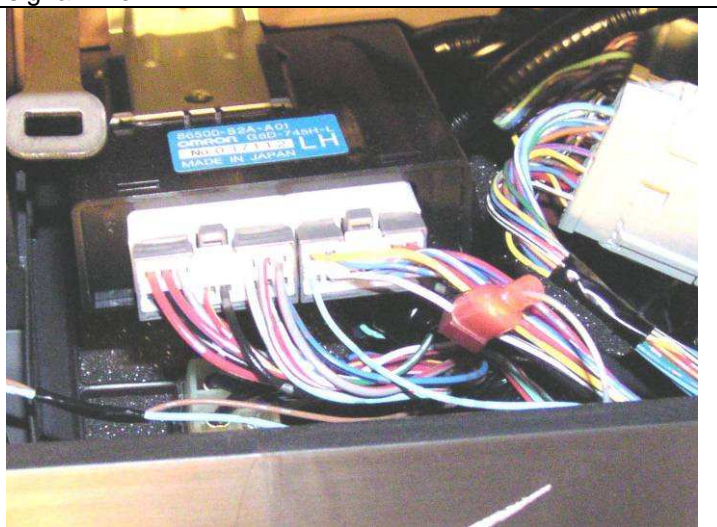

Photo 4 showing the DCI gray wire connected to the speed signal wire.



Operation of the DCI-2

Please note that the DCI does not operate exactly like the factory stereo controls. This is because the DCI provides extra functions and the fact that aftermarket head units use different commands than the factory head unit. Review the tables below to familiarize yourself with the commands before operating your DCI.

Tap-n-Press Feature – see dip switch settings to activate this feature

Tap-n-Press allows the DCI to perform different commands depending on how long you hold the MODE or CH button depressed before you release them. If you give the button a quick “Tap” you get one command; if you “Press” the button longer you get a different one. While this sounds confusing at first it’s actually very easy to use, and the benefit is that the most common commands are now on the easiest to hit buttons – Tap MODE and Tap CH.

A “Tap” is defined as holding the button for less than ½ second. A “Press” is when you hold the button longer than ½ second. If you look at the table below you will see that tapping the MODE button performs the Next Track function if you’re listening to CD or it does Seek Up if you’re in radio mode. If the MODE button is pressed longer than ½ second it will perform its “normal” function – changing sources. Likewise, the Disk Up and Next Radio Preset commands are on the CH button, so tapping CH allows you to change disks (or MP3 folders) if you’re listening to a CD or it will jump to the next preset when you’re in radio mode. A longer “Press” of the CH button does its normal AM/FM Band function.

In previous versions of the DCI these functions were only available through “button combinations” where you pressed two buttons at once. Those combinations are still there, but by activating Tap-n-Press you can perform the most common commands with a quick Tap of the MODE or CH buttons.

If you do not set the “Tap-n-Press” feature, the commands with the gray background will be performed when you use the MODE or CH button.

MUTE function – When the DCI puts the HU into MUTE mode it disables all the other dash controls, including the SCV function. This is because the head unit will come out of MUTE if it receives another command and that can be pretty annoying, especially if you have SCV enabled. When MUTE is cycled back OFF via the dash switch the other dash switches will be enabled and the DCI will adjust the volume based on your new speed (if it changed while you were muted).

Note: Because the DCI can only perform commands that are built into the head unit there are some limitations on where the commands are arranged or how they operate. Alpine and Kenwood are reasonably straight-forward but JVC and Clarion do some unusual things with the command set.

Dash Switch	Alpine	Kenwood	JVC	Clarion
MUTE	Mutes the audio output, some head units will pause CD playback depending on settings			
Volume Up/Dn	Tap to adjust volume up or down in steps, hold the switch to adjust rapidly up or down			
Tap MODE	Next track or Seek up	Next track or Seek up	Next track or Seek up	Next track or Radio Preset Up
Press MODE	Changes Source – Radio, CD, Aux input, CD Changer, etc.			
Tap CH	Disk Up or Radio Preset Up	Preset Up	Disk Down or Radio Preset Up	Next Disk (CD changer mode) or Next Band (in Radio mode) or Back to first track (single CD or MP3 mode)
Press CH	AM/FM Band	Disk Up or Next FM band	Sound (EQ settings)	
Hold MODE & Tap Vol Up	Next Track or Seek Up	Next Track or Seek Up	Next Track or Seek Up	Next track or Radio Preset Up
Hold MODE & Tap Vol Dn	Prev Track or Seek Down	Previous Track or Seek Down	Prev Track or Seek Down	Prev track or Radio Preset Dn
Hold CH & Tap Vol Up	Disk Up or Radio Preset Up	Disk Up or Next FM band	Disk Up or AM/FM Band	SCAN mode - press again to cancel SCAN
Hold CH & Tap Vol Dn	Disk Down or Radio Preset Dn	Disk Down or Next AM band	Disk Down or Radio Preset Up	Changes display (title, track, folder, etc)
Hold MODE & Tap CH	Toggles the SCV feature between your 2 selected settings			

The SCV (Speed Controlled Volume) Feature

The SCV feature operates by measuring vehicle speed and raising and lowering the volume at programmed speeds. The DCI has 14 "levels" of volume boost so you're sure to find one that suits your preference. Actually, you get to choose 2 levels and switch between them any time – just hold the MODE button and tap CH to toggle between the two SCV levels. Most users use the second SCV level to assign a more aggressive volume setting for Top Down driving. The DCI will remember the setting you last used until you change it. If you want to completely disable the SCV function, don't connect the vehicle speed sensor wire to the DCI or choose Level 0 as one of your two SCV settings and disable it via the MODE + CH buttons.

For all SCV levels the first Volume Up occurs at 15 mph. Subsequent Volume Ups are at different speeds depending on what SCV level you choose. Looking at the below chart you can see that higher SCV settings provide more frequent volume adjustments. The spacing between volume adjustments is called the 'interval', which is measured in mph. Higher SCV settings use smaller intervals, which provide more volume boost as you speed up.

Note: Even though the chart only shows three "Volume Up" commands the DCI will continue to raise the volume no matter how fast you go. Default settings are shown with a gray background. DCI-2 software revisions prior to .316 only have SCV levels 0 to 8.

SCV Level	Interval	First Volume Up	Successive Volume Ups	SCV Level	Interval	First Volume Up	Successive Volume Ups
0	SCV OFF – No volume adjustments						
1	29 mph	15	44, 73, 102	8	11 mph	15	26, 37, 48
2	25 mph	15	40, 65, 80	9	10 mph	15	25, 35, 45
3	21 mph	15	36, 57, 78	10	9 mph	15	24, 33, 42
4	19 mph	15	34, 53, 72	11	8 mph	15	23, 31, 39
5	17 mph	15	32, 49, 66	12	7 mph	15	22, 29, 36
6	15 mph	15	30, 45, 60	13	6 mph	15	21, 27, 33
7	13 mph	15	28, 41, 54	14	5 mph	15	20, 25, 30

The default programming is set for SCV levels 4 and 6 with level 4 being active when you first install the DCI. If you want to change these settings see the programming instructions on the next page. The 14 settings for the SCV function work pretty much the same - the only difference is how closely spaced the volume changes occur. It is easier to understand if I describe one setting in detail, and I'll use the '6' setting in my example.

When the DCI determines that vehicle speed has reached 15 mph, it sends one VOLUME UP command to the head unit. At every succeeding interval of 15 mph (for the '6' setting) it will send an additional VOLUME UP command, so that by the time you reach highway speeds (60 mph) the volume will have been increased 4 times. (15, 30, 45, and 60 mph)

As you slow down, the volume will be reduced, and if you were to stop, the volume will return to its initial setting. The difference is that when slowing down, the VOLUME DOWN commands occur at different speeds than when you speed up. There is a good reason for this, as I'll explain.

Let's assume you are driving on the Interstate at 60 mph. The volume will have been increased 4 times, at 15, 30, 45, and 60 mph. As you cruise at 60, it would be annoying if every time your speed wavered between 59 and 60 mph the volume lowered and then increased again. So the DCI was designed to wait till your speed slows significantly before dropping the volume. It must see the speed drop by 1/2 of the speed 'interval' before it makes a volume adjustment. In this example, the speed interval is 15 mph, so the volume will not decrease till you slow below 52.5 mph (half of 15 is 7.5). The effect is that if you are cruising at 60 mph, you will need to either speed up to 75 or slow down to 52 before a volume change occurs, which eliminates annoying volume changes if your speed varies just a little.

Bear in mind the DCI checks vehicle speed about once a second, so if you accelerate quickly you may notice the volume adjustments lag a little behind. Don't be concerned, it will catch up within a second or two and adjust the volume appropriately.

Programming the SCV Settings

Overview: (SCV = Speed-Controlled Volume)

There are 15 levels of SCV compensation, numbered 0 through 14, where 14 is the most aggressive volume adjustment and 0 disables SCV completely. You can program any two levels of SCV compensation and toggle between them anytime you want by holding MODE and tapping the CH button. Most owners will set a more aggressive SCV level for top-down driving and a lower setting for top-up or hard top use. (Note that you must change levels manually – the DCI has no way of knowing when you put the top up or down). You can also set one of the levels to 0 so you can conveniently turn SCV off using the MODE + CH button combination.

From the factory, SCV levels 4 and 6 are programmed into the DCI so it will work as soon as you install it. You do not need to perform the SCV programming procedure unless you want to change the SCV levels. I'd suggest using the DCI with the factory settings to get a feel for how it works before you try changing them.

The programming procedure is initiated via a special power-on sequence, after which you use the dash switches to set and save the two SCV levels you want to use. The programming process is fairly simple because it is "interactive"; using the HU display to indicate which SCV level you are setting. Refer to the SCV chart on the previous page to determine which two SCV settings you want to use, then program them using the following procedure.

Procedure: Do NOT attempt to program the SCV levels while driving (DUH!)

1. First make sure the DCI is installed and working correctly. Note: It's easier to verify your programming is correct if you leave the "Tap-n-Press" dip switch OFF, at least the first time you set the SCV levels.
2. Turn the ignition to ACC, change Sources on your HU to FM radio mode, and set the volume to minimum (zero).
3. Turn the ignition OFF.
4. Hold the dash MODE button depressed and turn the ignition to ACC (this activates Program Mode).
5. Wait a second, and then release the MODE button.
6. Do NOT press any dash buttons or HU controls until the HU has finished powering up.
7. Once the HU is booted, press the dash Volume Up switch once and verify the HU changes volume and the display indicates the volume level is "1". Each time you press Volume Up the DCI sends a Volume Up command and also increments the internal SCV level, so the volume displayed on the head unit keeps step with the DCI SCV setting. You can use Volume Up and Volume Down to adjust the volume anywhere between 0 and 14. During Program Mode you cannot select a volume setting outside this range because it's not a valid SCV value.
8. Continue pressing the Volume Up or Down buttons to set the volume indicator to your first SCV level. Once you have selected the SCV setting you want, press the MODE button one time. The HU will change AM/FM bands (or in some cases the Preset Station) as an indication that the first SCV level was accepted and saved to memory.
9. Now use the Volume switches to set the second SCV level and press MODE to save it. The HU will again change AM/FM bands (or Presets) and then exit Programming Mode.

If you made a mistake or want to change the SCV levels, just repeat the Programming steps.

Notes:

1. Hint – Pioneer head units seem to require more aggressive SCV settings, try Level 9 or above
2. The above instructions say the HU will change AM/FM Bands when you save the SCV level (by pressing MODE). In actuality the HU will perform the command normally assigned to the CH button. For 90% of HU that is the AM/FM Band command, but for some goofy HU like Kenwood, JVC, or Clarion it will do something else. If you have one of these HU you can see which command it will perform by looking at the Operation section of this manual. It's not that important, but I didn't want you to be confused when your JVC activates the EQ display.
3. You can re-program the SCV levels any time you want, as often as you want.
4. Do NOT press and hold the Volume switches during Program Mode. The DCI will repeat volume commands very quickly and the HU may not reflect the true SCV setting. Adjust the volume in single steps to be sure the HU stays in step with the counter in the DCI.
5. During Programming Mode the dash MUTE switch is active, so don't press it. In some cases it will prevent Volume commands from working and the HU will not correctly indicate the SCV level you are setting.
6. The SCV level is not saved till you press MODE, so it doesn't matter how many times you change the volume between 0 and 14. All that matters is where it's set when you press the MODE button to save it.
7. If you have one of those silly head units that does not indicate volume levels or does not display single steps you will have to count the number of times you hit Volume Up to know which SCV level you are setting. Just remember that Program Mode always starts at level 0 and after you set the first SCV level it remains at that level (does NOT return to 0) and you should adjust it up or down from there to select the second SCV level.

DCI-2 Dip Switch Settings

Switch 1 - Mute Control - This switch is normally set to OFF (down) sending mute commands via the DCI blue wire to the head unit ATT or Cell Phone lead. If your head unit does not have a separate ATT or Cell phone wire you should change switch 1 to ON (up) so the DCI sends the MUTE command via the 3.5mm cable/white wire.

If you are using a Blue Tooth adapter module and your ATT/Cell Phone wire is connected to the BT module you should set switch 1 ON (up) so the DCI and BT module do not "fight" each other.

Remember to insulate the DCI blue wire if you don't use it for the mute function.

Switch 2 - Tap-n-Press – This switch activates the "Tap-n-Press" feature which changes how the MODE and CH dash buttons work. With switch 2 OFF the Tap-n-Press feature is not activated, and the MODE and CH buttons act "normal", sending the same command no matter how you press them. Setting switch 2 ON activates "Tap-n-Press" and the DCI will perform different commands depending on how long you hold MODE or CH before you release them. If you "Tap" the button for less than ½ second you get one command and if you "Press" the button longer than ½ second you get another command.

While this sounds confusing at first it's actually very easy to use, and the benefit is that the most common commands (next track and next preset station) are now on the easiest to hit buttons – Tap MODE and Tap CH. See the Operation section of this manual for details on how the Tap-n-Press feature works on your head unit.

Switches 3 & 4 - Head Unit Brand – Set these switches for your head unit brand.

Trouble getting your DCI to work?

Do not return products without prior authorization – credit will NOT be issued. All items are subject to a re-stocking charge of 20%. Products that have been installed will be assessed an additional fee to cover replacement of the wire harness or other items necessary to return the product to a salable condition.

All DCIs are fully tested using a live head unit and a dash control mockup. We even generate speed signals to test the SCV auto-volume function, so chances are your DCI arrived in working order. But if you're having trouble getting it to work, try these suggestions.

1. Review the operating instructions. After-market head units do NOT work like the OEM head unit and some users think there's something wrong when the dash switches do different commands – it's the head unit, not the DCI.
2. Verify wiring and switch settings. Get a friend to review your work; it helps to have someone who hasn't been staring at it for 2 hours look it over.
3. Check out the extensive troubleshooting help at our web site – <http://www.modify.com/products/dci/help.htm> and <http://www.modify.com/products/dci/tech.htm>. There are lots of tests you can do without complicated test equipment. If you contact us with a problem we're going to refer you there anyway, or we'll ask questions to verify you have done your homework. Customers that have done some troubleshooting in advance typically get their problems resolved much quicker because we don't have to ask 20 questions.
4. Email the guru – bob@modify.com for help. Many problems can be solved via email support.
5. If we're unable to fix your problem "remotely" we'll probably ask you to return the product to us for troubleshooting. Shipping to us is your responsibility, so make sure the item doesn't get lost or is insured against loss. Products cannot be replaced if lost in transit.

↑ = dip switch up (ON)

↓ = dip switch down (OFF)

Mute Control

Switch #→	1
3.5mm Plug	↑
Blue Wire	↓

Tap-n-Press

Switch #→	2
ON	↑
OFF	↓

Head Unit Brand

Switch #→	3	4
Alpine	↑	↑
Kenwood	↓	↑
JVC	↑	↓
Clarion	↓	↓